

Processor Components

Abstraction!

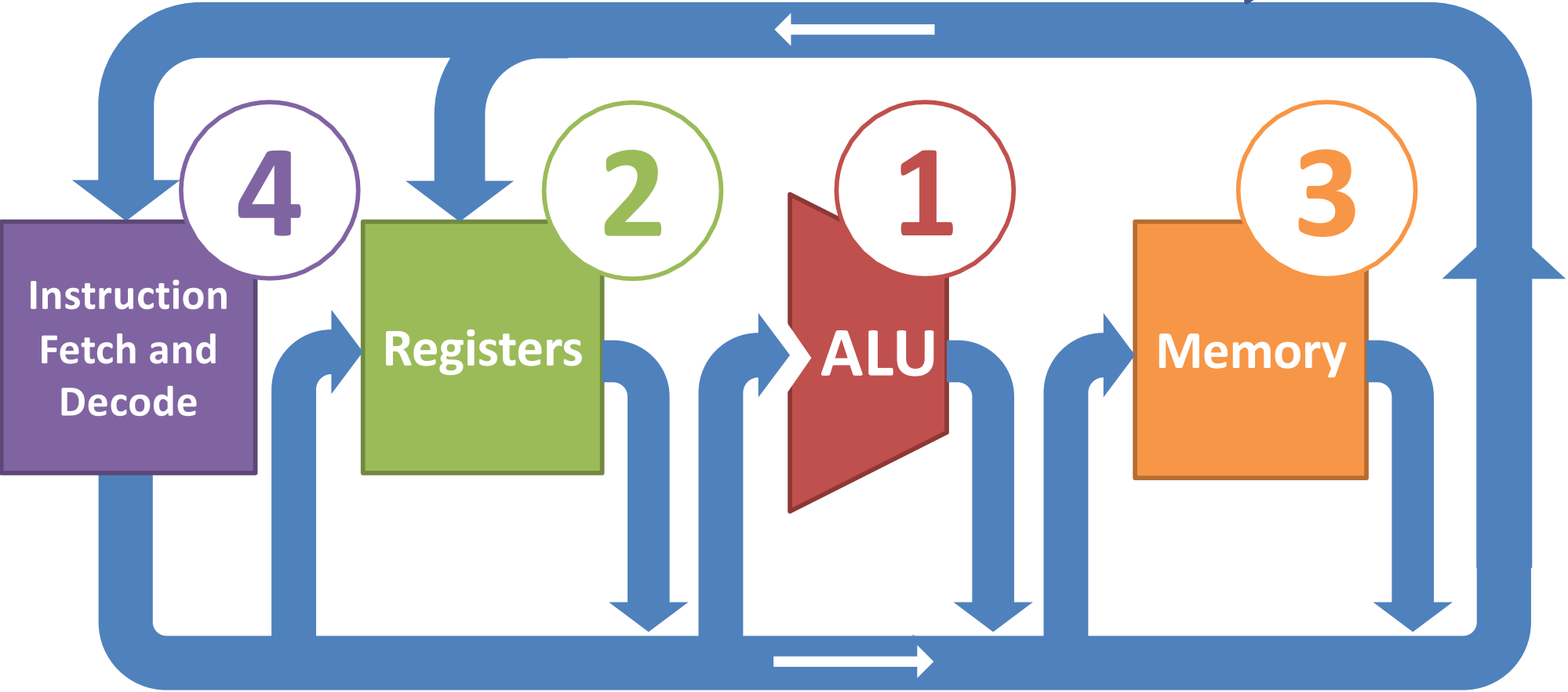

Arithmetic Logic Unit (ALU)

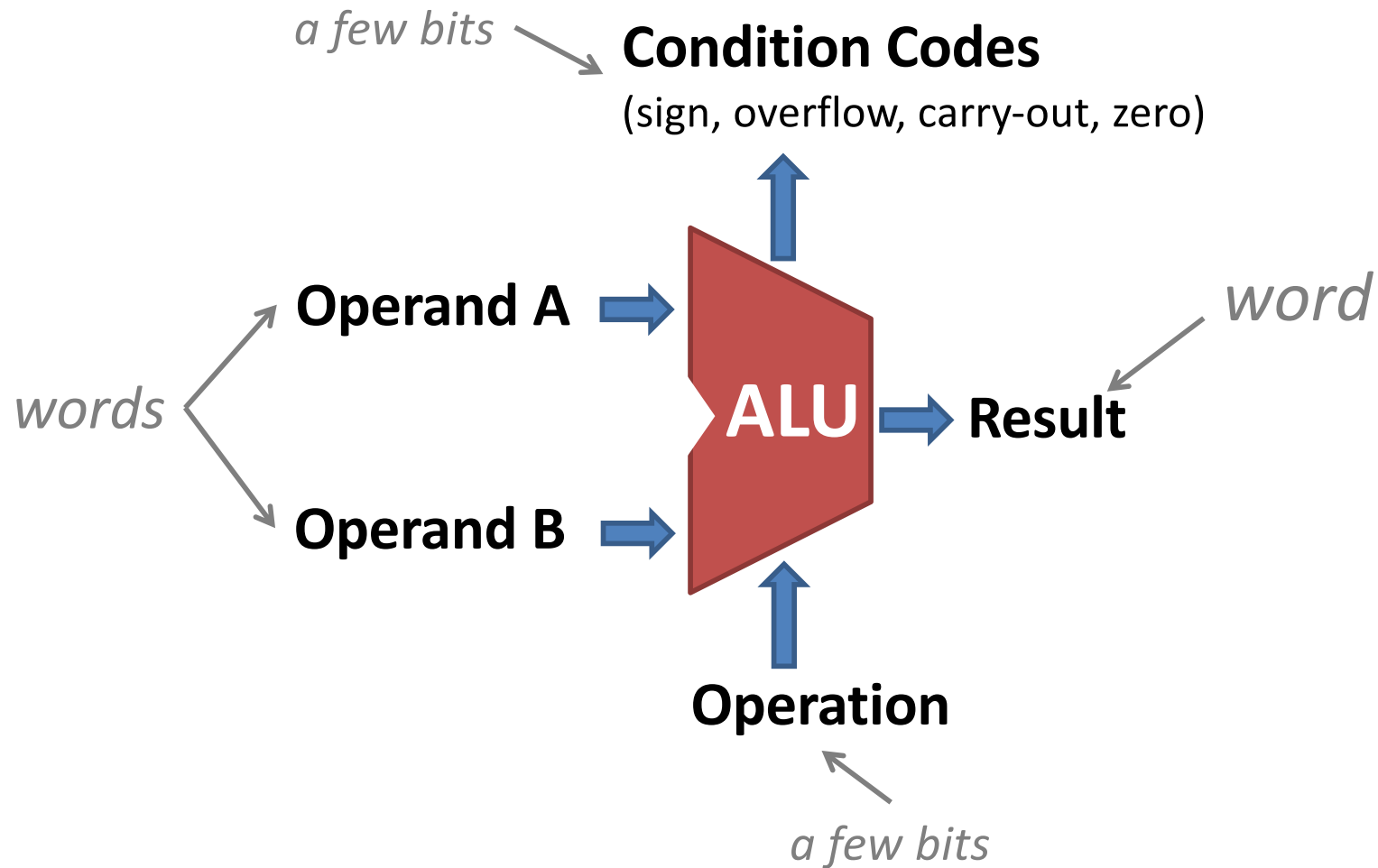

Hardware unit for arithmetic and bitwise operations.

1-bit ALU for bitwise operations

Build an n-bit ALU from n 1-bit ALUs.

Each bit i in the result is computed from the corresponding bit i in the two inputs.

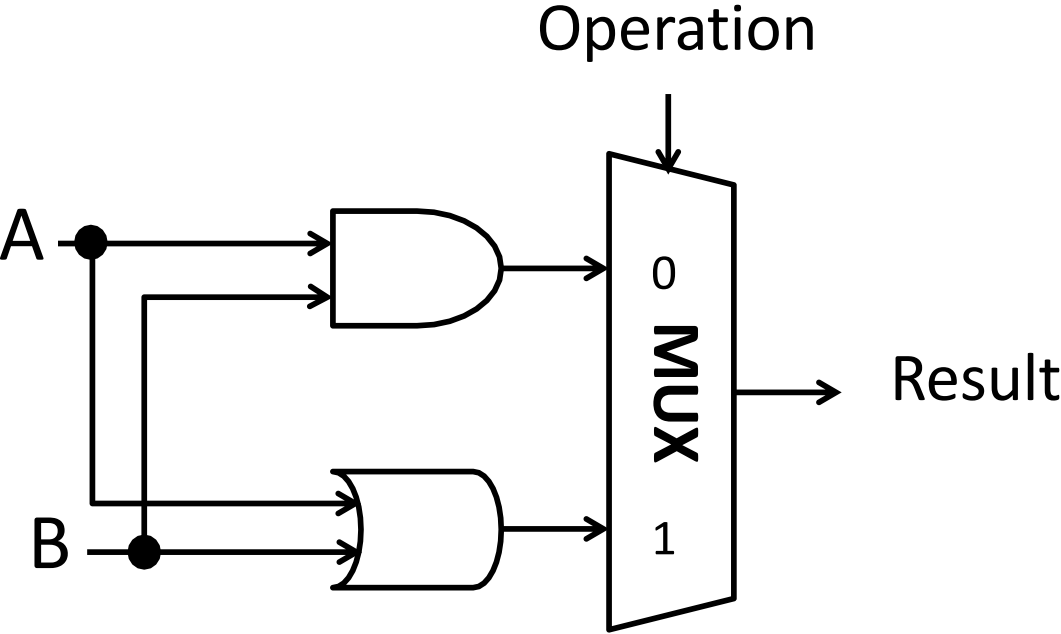

Op	A	B	Result
0	0	0	
0	0	1	
0	1	0	
0	1	1	
1	0	0	
1	0	1	
1	1	0	
1	1	1	

Addition:

start small with a 1-bit (half) adder



A

B

Sum

Carry out

A	B	Carry out	Sum
0	0		
0	1		
1	0		
1	1		

1-bit full adder

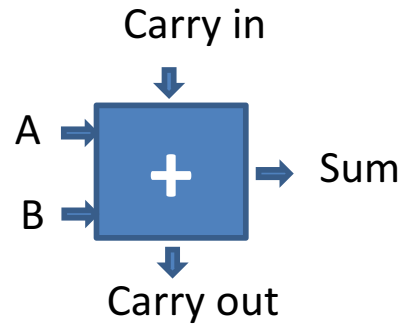

n-bit addition: $Sum_i = A_i + B_i + CarryOut_{i-1}$

Need a bigger adder!

Carry in

A

B

Sum

Carry out

A	B	Carry in	Carry out	Sum
0	0	0		
0	0	1		
0	1	0		
0	1	1		
1	0	0		
1	0	1		
1	1	0		
1	1	1		

n-bit ripple carry adder

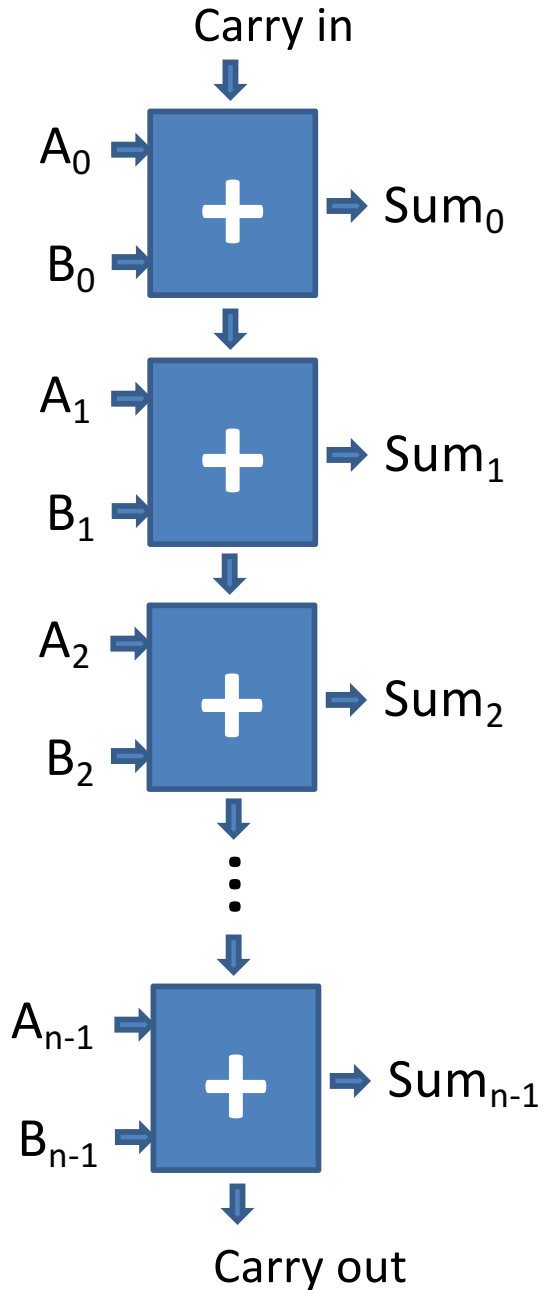

n-bit ALU

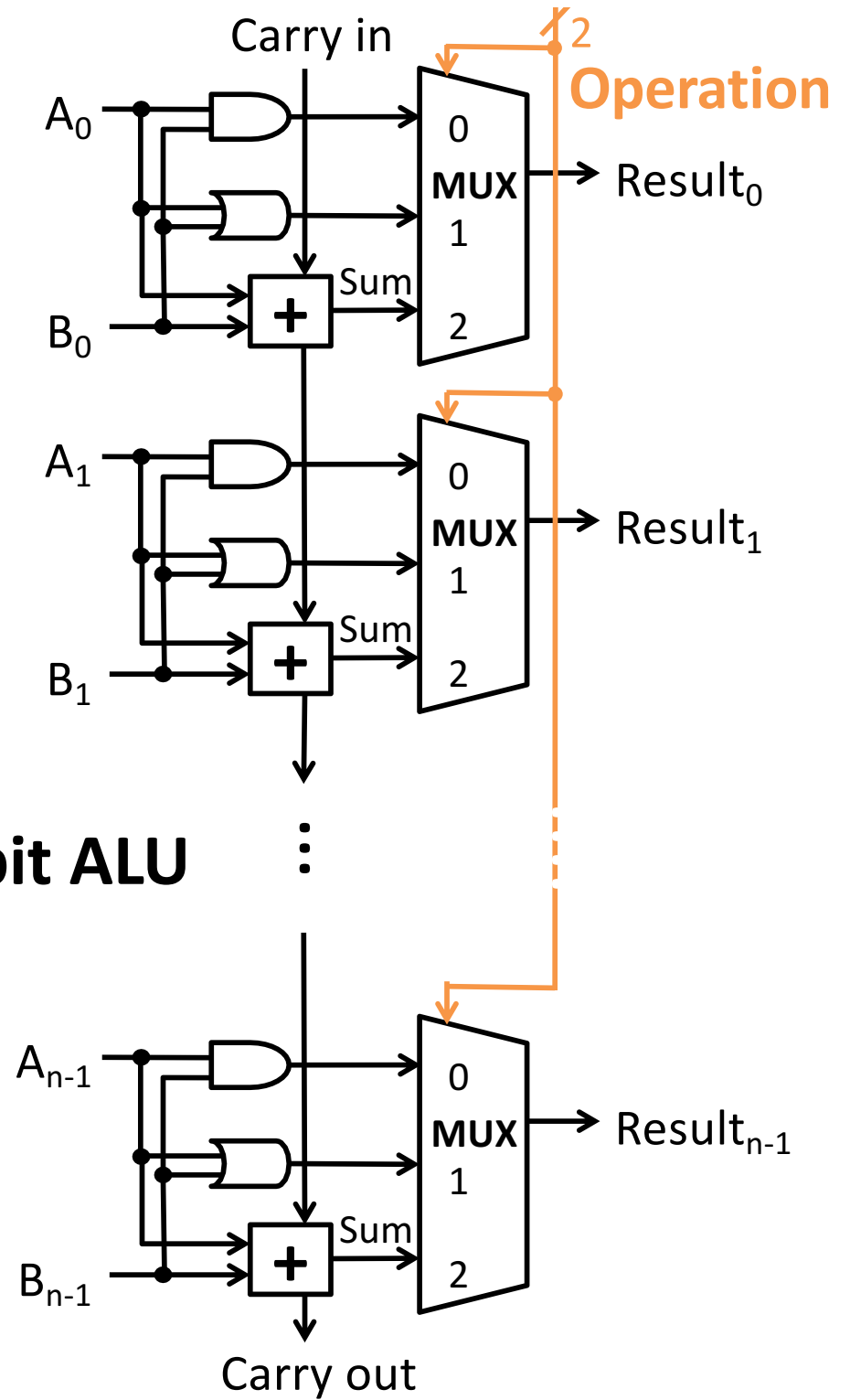

ALU conditions

Extra ALU outputs

describing properties of result.

Zero Flag:

1 if result is 00...0 else 0

Sign Flag:

1 if result is negative else 0

Carry Flag:

1 if carry out else 0

(Signed) Overflow Flag:

1 if signed overflow else 0

Implement these.

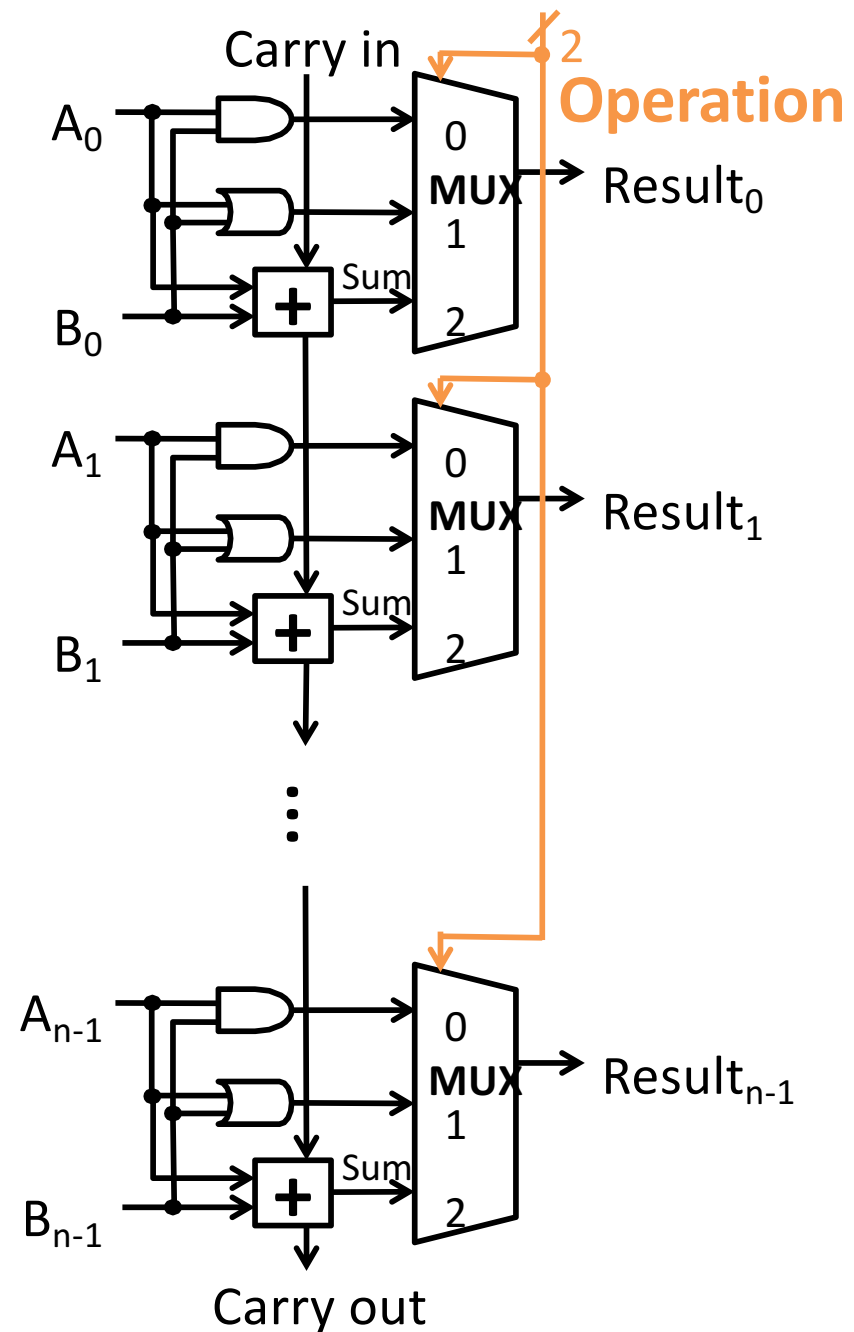

Add subtraction

How can we control ALU inputs or add minimal new logic to compute **A-B**?

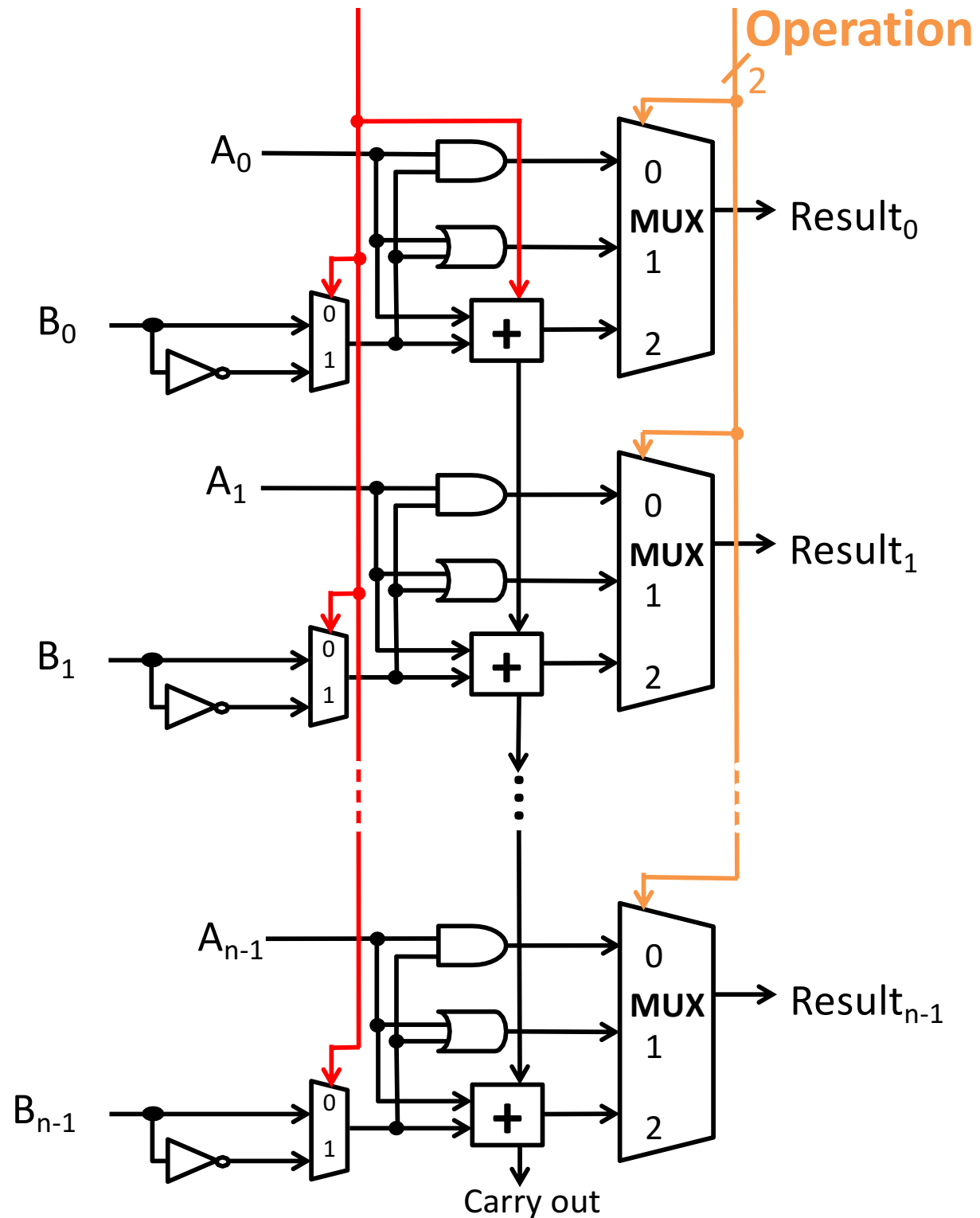

$\sim(A \& B)$

$\sim(A | B)$

$A < B$

$A == B$

How can we control ALU inputs or add minimal new logic to compute each?

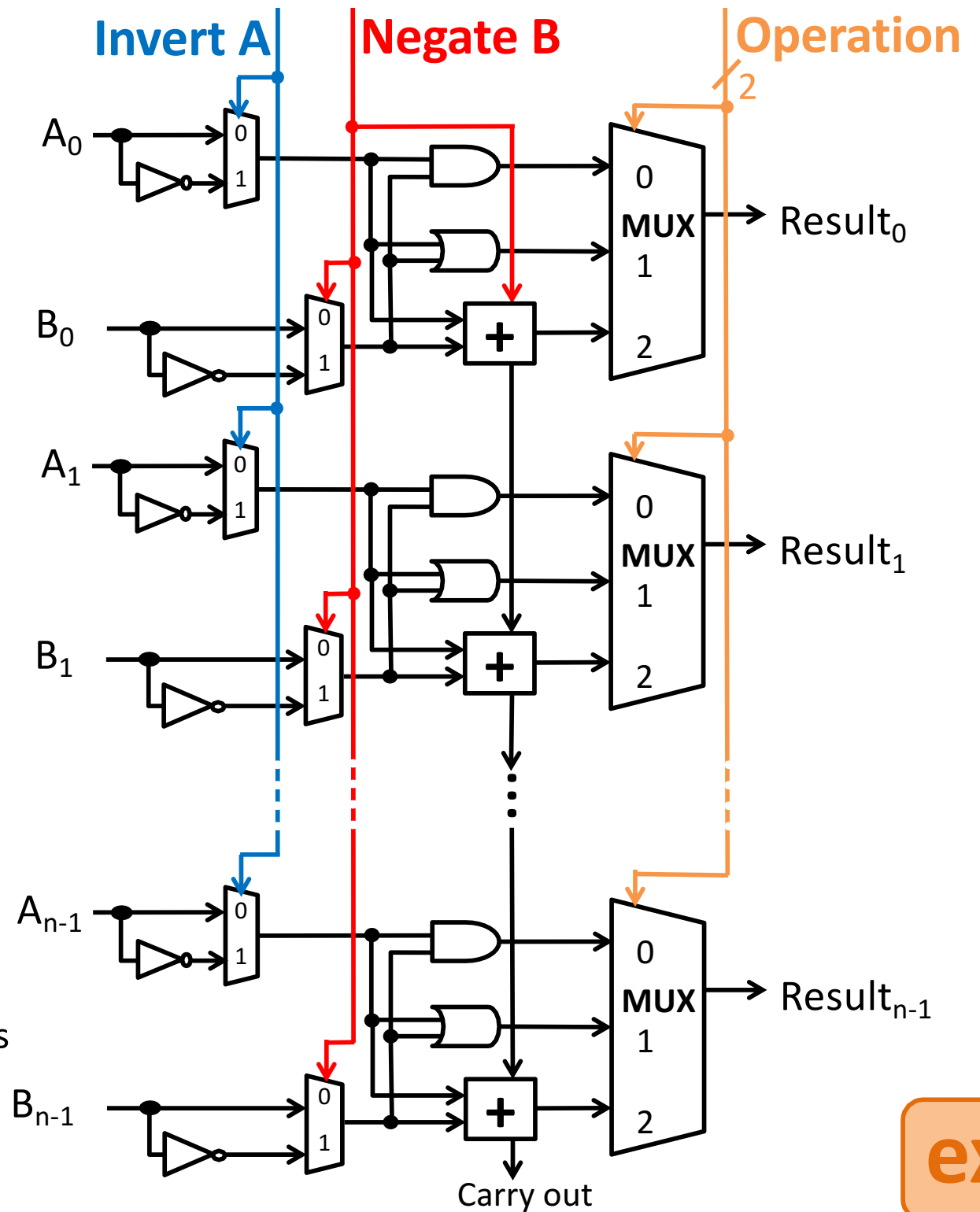

Controlling the ALU



ALU control lines	Function
0000	AND
0001	OR
0010	add
0110	subtract
1100	NOR

