



Basic building blocks

Common combinational circuits: encoders, decoders, multiplexers

But first...

Recall: *sum of products*

logical sum (OR)

of products (AND)

of inputs or their complements (NOT).

A	B	C	M
0	0	0	0
0	0	1	0
0	1	0	0
0	1	1	1
1	0	0	0
1	0	1	1
1	1	0	1
1	1	1	1

Construct with:

- 1 code detector per 1-valued output row
- 1 large OR of all code detector outputs

Is it minimal?

Gray Codes = reflected binary codes

Alternate binary encoding

designed for electromechanical switches and counting.

			00	01		11	10		
			0	1		2	3		
000	001	011	010		110	111	101	100	
0	1	2	3		4	5	6	7	

How many bits change when incrementing?

Karnaugh Maps: find minimal sums of products

A	B	C	D	F(A, B, C, D)
0	0	0	0	0
0	0	0	1	0
0	0	1	0	0
0	0	1	1	0
0	1	0	0	0
0	1	0	1	0
0	1	1	0	1
0	1	1	1	0
1	0	0	0	1
1	0	0	1	1
1	0	1	0	1
1	0	1	1	1
1	1	0	0	1
1	1	0	1	1
1	1	1	0	1
1	1	1	1	0

		CD			
		gray code			
		order →			
		00	01	11	10
AB	00	0	0	0	0
	01	0	0	0	1
	11	1	1	0	1
	10	1	1	1	1

1. Cover exactly the 1s by drawing maximally sized rectangles whose dimensions (in cells) are powers of 2. (They may overlap or wrap around!)
2. For each rectangle, make a *product* of the inputs (or complements) that are 1 for all cells in the rectangle. (*minterms*)
3. Take the *sum* of these products.

Voting again with Karnaugh Maps



A	B	C	M
0	0	0	0
0	0	1	0
0	1	0	0
0	1	1	1
1	0	0	0
1	0	1	1
1	1	0	1
1	1	1	1

Building Blocks

Microarchitecture

Digital Logic

Devices (transistors,
etc.)



Processor datapath

Instruction Decoder
Arithmetic Logic Unit

Memory

Adders
Multiplexers
Demultiplexers
Encoders
Decoders

Registers

Flip-Flops
Latches

Gates



Decoders

Decodes input number, asserts corresponding output.

n -bit input (an unsigned number)

2^n outputs

Built with code detectors.

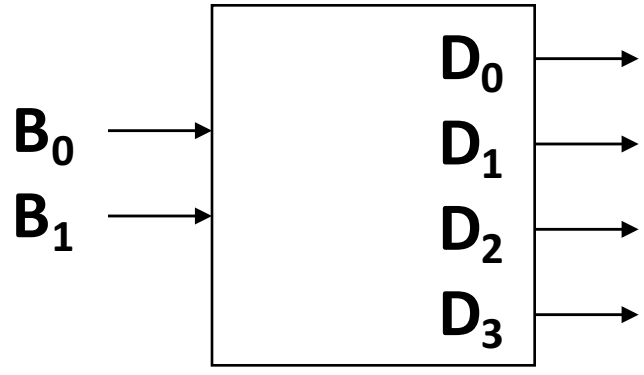
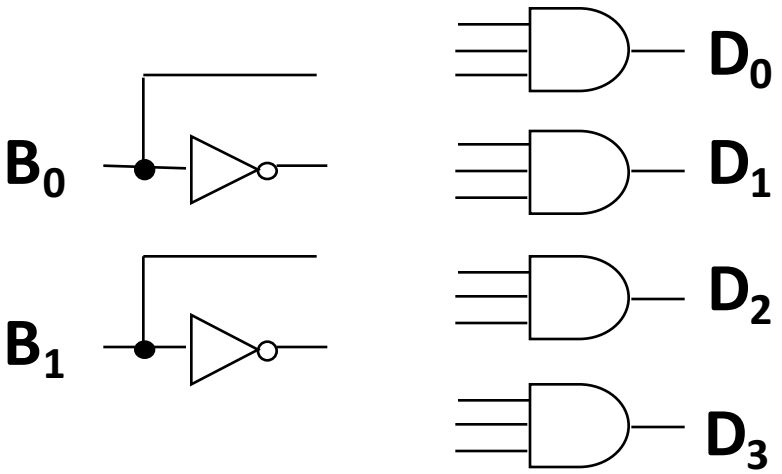

Multiplexers

Select one of several inputs to forward as output.

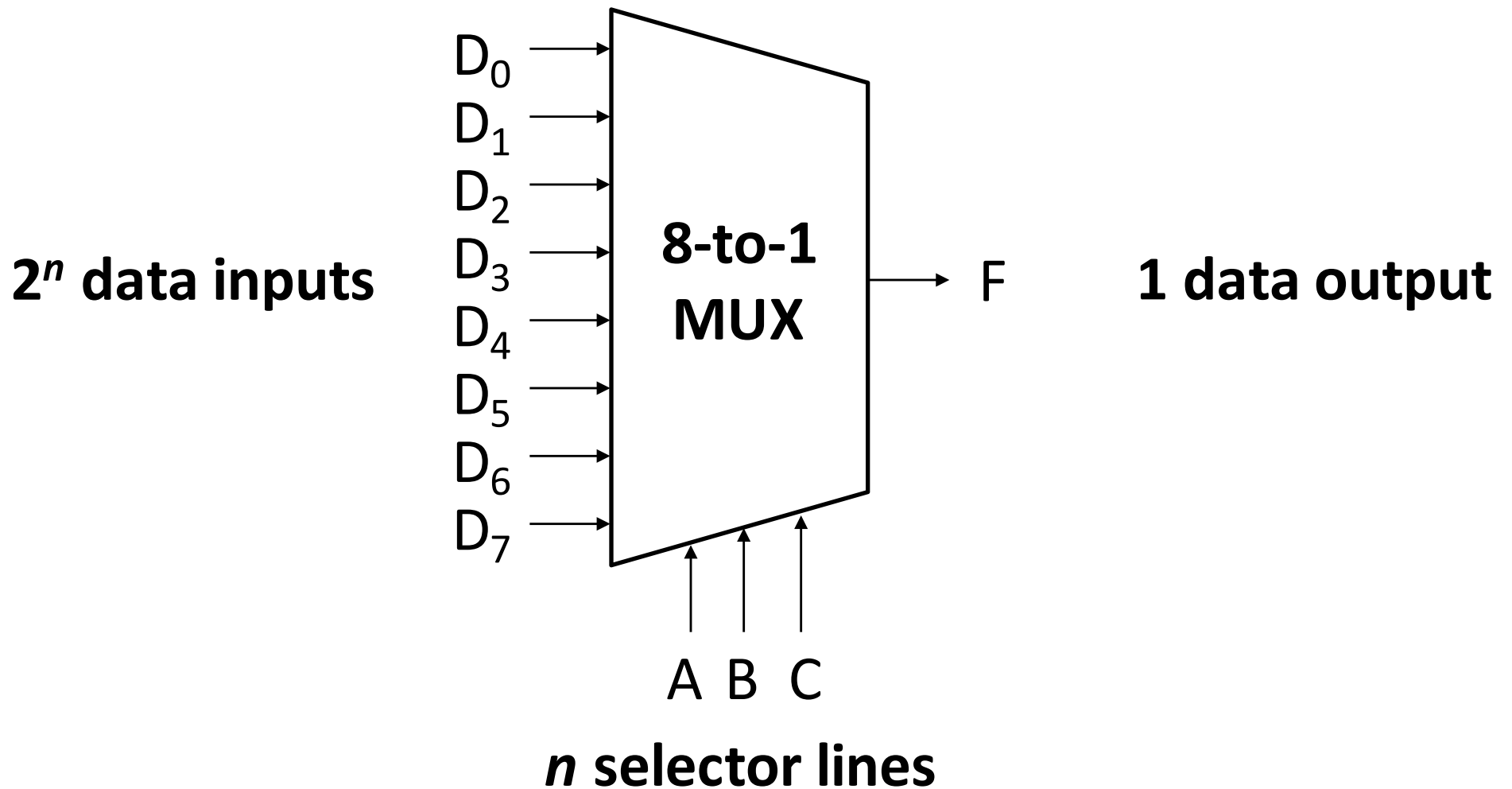

Build a 2-to-1 MUX from gates

ex

If $S=0$, then $F=D_0$.

If $S=1$, then $F=D_1$.

1. Construct the truth table.

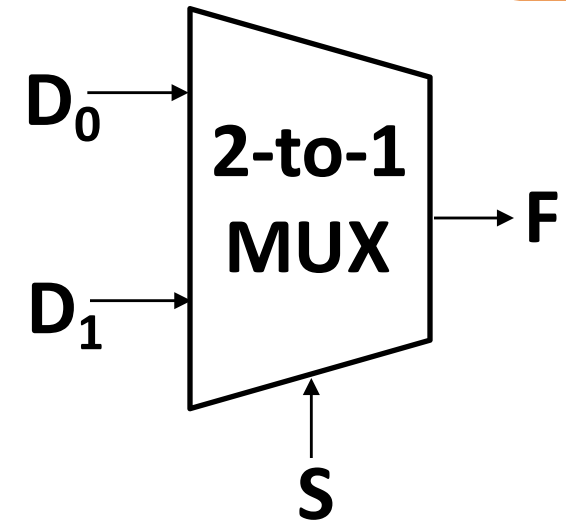

2. Build the circuit.

8-to-1 MUX

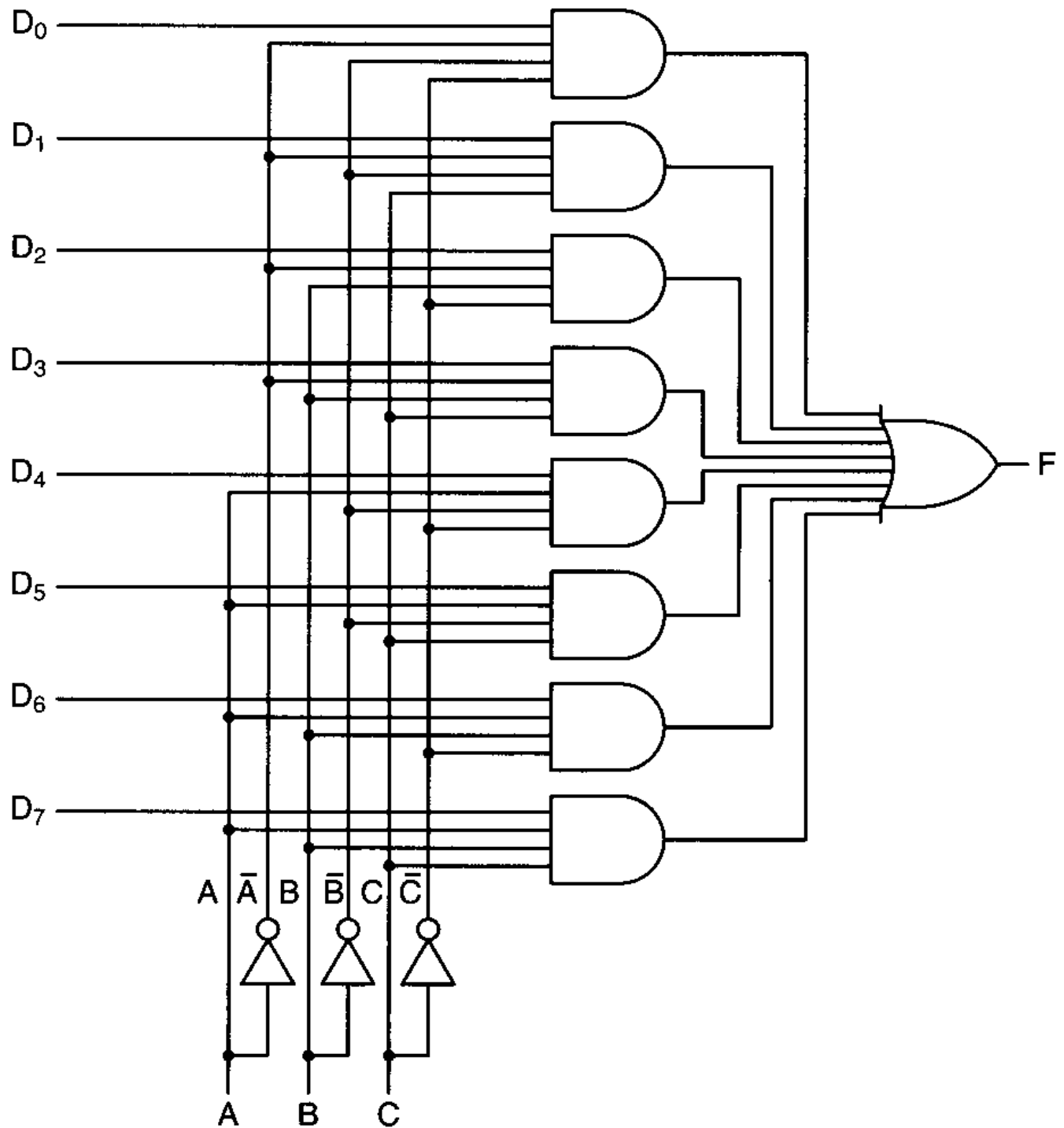

Costume idea: MUX OX

MUX + voltage source = truth table

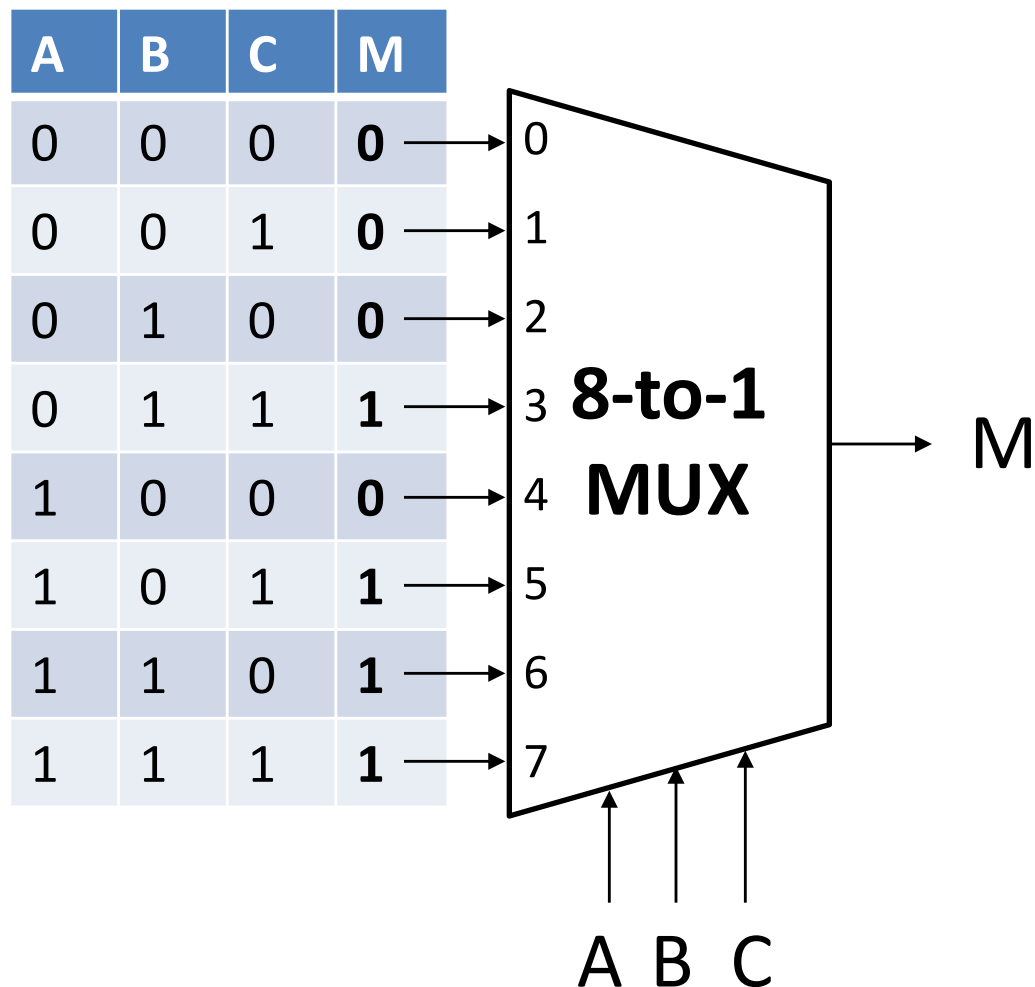

Buses and Logic Arrays

A **bus** is a collection of data lines treated as a single logical signal.

= **fixed-width value**

Array of logic elements applies same operation to each bit in a bus.

= **bitwise operator**

