



# Combinational Logic

Karnaugh maps

Building blocks: encoders, decoders, multiplexers



But first...

## Recall: *sum of products*

logical sum (OR)

of products (AND)

of inputs or their complements (NOT).

A	B	C	M
0	0	0	0
0	0	1	0
0	1	0	0
0	1	1	1
1	0	0	0
1	0	1	1
1	1	0	1
1	1	1	1

Construct with:

- 1 code detector per 1-valued output row
- 1 large OR of all code detector outputs

Is it minimal?

## Gray Codes = reflected binary codes

Alternate binary encoding

designed for electromechanical switches and counting.

00	01	11	10				
0	1	2	3				
000	001	011	010	110	111	101	100
0	1	2	3	4	5	6	7

How many bits change when incrementing?

## Karnaugh Maps: find (minimal) sums of products



				CD				
				gray code order				
				00	01	11	10	
A	B	C	D	F(A, B, C, D)	0	0	0	0
0	0	0	0	0	0	0	0	0
0	0	0	1	0	0	0	0	0
0	0	1	0	0	0	0	0	0
0	0	1	1	0	0	0	0	1
0	1	0	0	0	0	0	0	0
0	1	0	1	0	0	0	0	0
0	1	1	0	0	0	0	0	0
0	1	1	1	0	0	0	0	1
1	0	0	0	1	1	1	1	1
1	0	0	1	1	1	1	1	1
1	0	1	0	1	1	1	1	1
1	0	1	1	1	1	1	1	1
1	1	0	0	1	1	1	1	1
1	1	0	1	1	1	1	1	1
1	1	1	0	1	1	1	1	1
1	1	1	1	0	1	1	1	1
1	1	1	1	0	1	1	1	1

1. Cover exactly the 1s by drawing a (minimum) number of maximally sized rectangles whose dimensions (in cells) are powers of 2. (They may overlap or wrap around!)
2. For each rectangle, make a *product* of the inputs (or complements) that are 1 for all cells in the rectangle. (*minterms*)
3. Take the *sum* of these products.

# Voting again with Karnaugh Maps



A	B	C	M
0	0	0	0
0	0	1	0
0	1	0	0
0	1	1	1
1	0	0	0
1	0	1	1
1	1	0	1
1	1	1	1

# Goal for next 2 weeks: Simple Processor

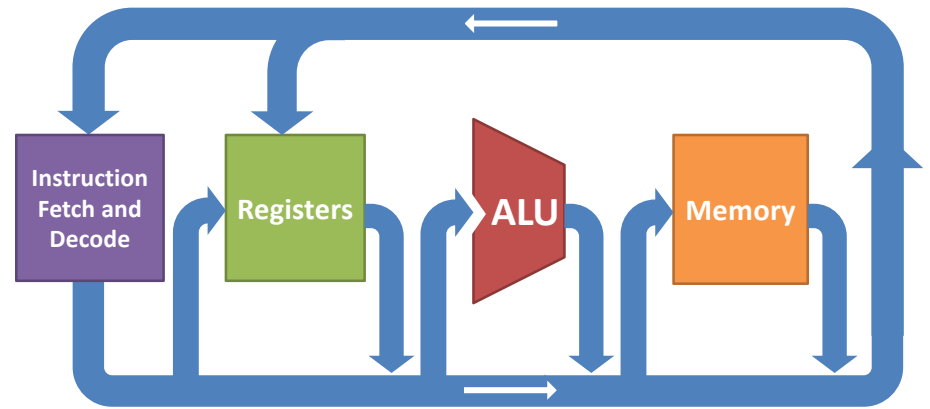

# Toolbox: Building Blocks



Processor datapath

Microarchitecture

Instruction Decoder  
Arithmetic Logic Unit  
Memory

Digital Logic

Adders  
Multiplexers  
Demultiplexers  
Encoders  
Decoders  
Gates  
Registers  
Flip-Flops  
Latches

Devices (transistors, etc.)



# Decoders



Decodes input number, asserts corresponding output.

$n$ -bit input (an unsigned number)

$2^n$  outputs

Built with code detectors.

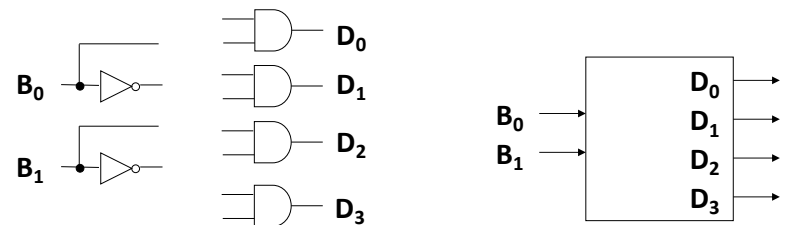

# Multiplexers

Select one of several inputs as output.

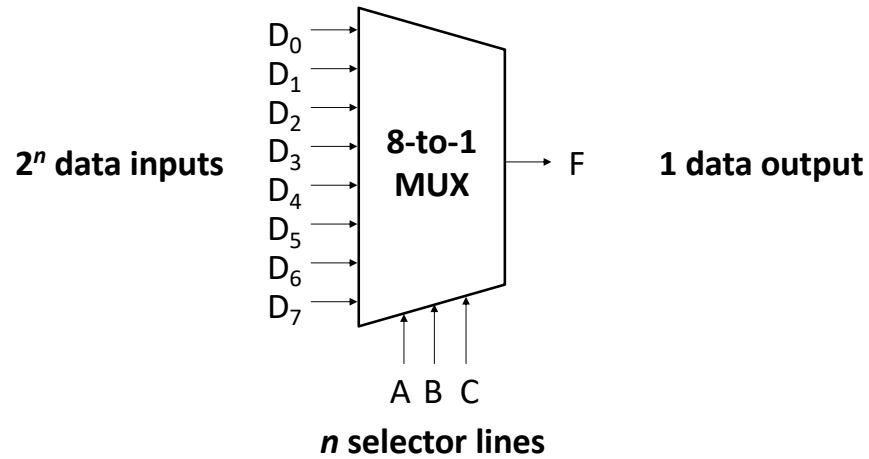

# Build a 2-to-1 MUX from gates



If  $S=0$ , then  $F=D_0$ .  
If  $S=1$ , then  $F=D_1$ .

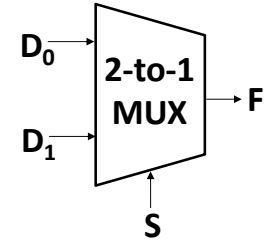

1. Construct the truth table.
2. Build the circuit.

# 8-to-1 MUX

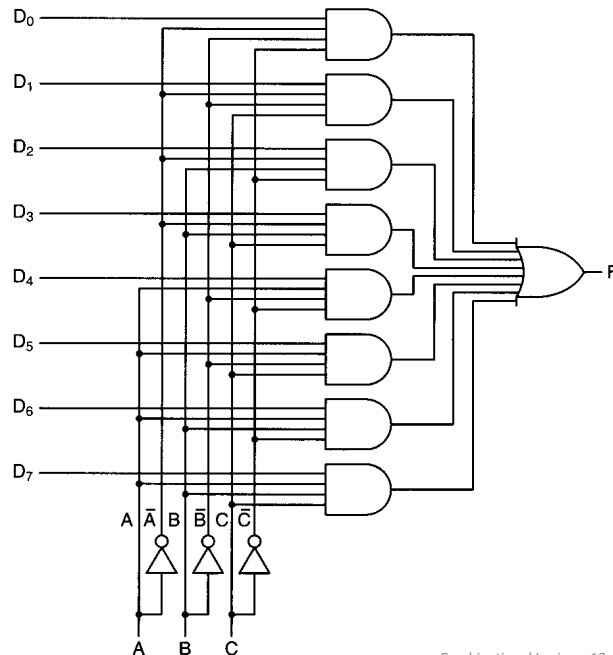

Costume idea: MUX OX

# MUX + voltage source = truth table

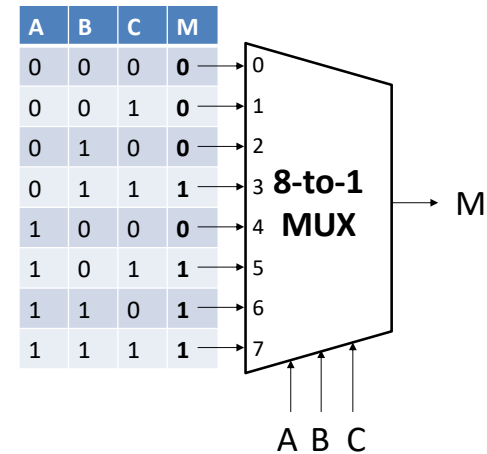

# Buses and Logic Arrays

A bus is a collection of data lines treated as a single logical signal.

= fixed-width value

Array of logic elements applies same operation to each bit in a bus.

= bitwise operator

